

# Properties of the Visual Channels that Underlie Adaptation to Gradual Change of Luminance

KARIN ARNOLD,\* STUART ANSTIS†

Received 15 February 1991; in revised form 5 June 1992

---

**Following adaptation to a spatially uniform patch of light that is gradually brightening (or dimming), a steady test patch appears to be gradually dimming (or brightening). We measured this ramp aftereffect with a nulling method, as a function of the amplitude and temporal repetition rate of the adapting sawtooth waveform and at various retinal eccentricities and levels of dark adaptation. We conclude that the underlying visual channels respond best to large-amplitude sweeps in luminance of at least 20 dB (1 log unit); but they are fairly insensitive to the temporal rate of this sweep. The channels are present out to an eccentricity of at least 40° but they almost disappear during dark adaptation. The ramp aftereffects were asymmetrical: the subjectively darkening aftereffect produced by a brightening adapting ramp was slightly stronger than vice versa.**

Psychophysics Ramp aftereffect Eccentricity Dark adaptation Luminance increment Asymmetry

---

## INTRODUCTION

It is a truism that the visual system is designed to respond better to changing stimuli than to steady states. A retinally stabilized image rapidly fades from view because of the transient responsiveness of the retinal receptors, and in general, visual coding is thought to edit out unchanging, redundant stimulation and pass on for later processing only changes in the visual array. Changes indicate that something of potential interest is happening. In computer graphics a common technique for storing a movie is not to specify each frame separately, since the unchanging backgrounds across frames are redundant. Instead it is customary to store on the first frame completely and then to specify only the frame-to-frame changes. The visual system's predilection for reporting only changes betokens a similar strategy. (Similar techniques eliminate spatial redundancy. Computers can compress spatially uniform areas by means of "run length encoding", specifying only that the next  $n$  pixels have the same color. The visual system also seems to report only contours, not uniform areas. However, this paper is concerned with temporal, not spatial changes.)

This being so, it makes sense to look for neural "change detectors". Years ago we found evidence for

this, in the form of a visual "ramp aftereffect" (Anstis, 1967). Following adaptation to a spatially uniform patch of light that is growing gradually brighter, a subsequently viewed static gray test patch appears to be growing gradually dimmer. Conversely, following adaptation to a patch that is growing gradually dimmer, a gray test patch appears to be growing gradually brighter (Anstis, 1967; Hanly & Mackay, 1979; Cavanagh & Anstis, 1986; Anstis & Harris, 1987). A single rising or falling adapting ramp is sufficient to produce a detectable aftereffect, but it is convenient in practice to use an adapting field that is modulated over time by a repetitive ramp or sawtooth. During the aftereffect the test stimulus appeared to brighten or darken monotonically. In Fig. 1(a) the solid black lines show the luminance profile of the stimulus over time and the gray arrows show the perceived aftereffect. The adapting stimuli are depicted as ramps, but since the human visual system has a logarithmic response to intensity, the stimuli actually varied logarithmically at a constant number of decibels per second of time (20 dB = 1 log unit).

Various forms of sweep (or continuous change) detector have been discovered in sensory systems. Zaidi and Halevy (1990) have reported evidence for mechanisms that signal color changes. In the auditory domain, Reinhardt-Rutland and Anstis (1982) found auditory adaptation to gradual change of intensity. They reported that following adaptation to a ramp-modulated loudening (or softening) tone, a steady test tone appeared to be getting gradually softer (or louder). Audio frequency sweep detectors have also been demonstrated. Kay and

---

\*Human Performance Laboratory, Institute for Space & Terrestrial Science, York University, 4850 Keele Street, North York, Ontario, Canada M3J 1P3.

†Department of Psychology, UC San Diego, La Jolla, CA 92093, U.S.A.

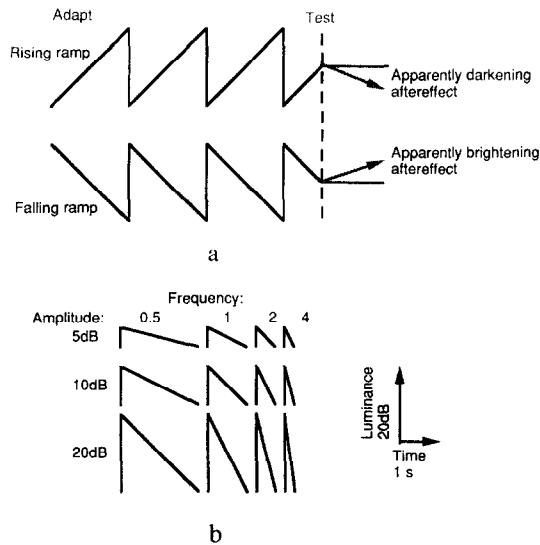

FIGURE 1. (a) Following adaptation to a patch whose luminance is modulated with a repetitively rising sawtooth, a static test patch shows an aftereffect of apparent darkening (upper gray arrow). Conversely, adaptation to repetitive dimming gives rise to an aftereffect of apparent brightening (lower gray arrow). (b) Amplitudes and repetition rates of the adapting stimuli in Expt 1. Only the falling ramps are shown.

Matthews (1972), Regan and Tansley (1979) and Gardner and Wilson (1979) found that adaptation to amplitude modulated tones raised the detection threshold for amplitude modulation and adaptation to frequency modulated tones raised the detection threshold for frequency modulation, but there was no cross-adaptation between FM and AM. Thus the auditory system contains separate channels selective for changes in frequency and in amplitude. The presence of these various channels, tuned to detect temporal modulations of intensity or wavelength/frequency both in the visual and the auditory domains, suggests that the detection of gradual changes over time in stimulus properties is an important strategy employed by sensory systems. By examining the behavior of visual change detectors we hope to throw light on this sensory strategy, using adaptation and negative aftereffects which are popular psychophysical tools for examining channels in the visual system. In this note we measure the "ramp aftereffect" as a tool for understanding the visual pathways that respond to gradual changes of luminance. We measured the ramp aftereffect as a function of the amplitude and repetition rate of the adapting stimulus, monocularly and binocularly and at different eccentricities and levels of dark adaptation.

#### EXPERIMENT 1: RAMP AFTERAFFECT AS A FUNCTION OF ADAPTING AMPLITUDE AND TEMPORAL FREQUENCY

##### Method

The luminance of a spatially uniform field was modulated over time by a sawtooth waveform from a computer-controlled frequency generator. The display was a high-speed raster on a Tektronix CRT screen with a green P31 phosphor, subtending  $13^\circ$  high  $\times$   $11^\circ$  wide and

surrounded by white cardboard. This cardboard surround was illuminated with green light which had the same geometric mean photopic luminance ( $19.5 \text{ cd/m}^2$ ) and approximately the same hue as the display. A black spot was provided on the center of the screen, which the subjects viewed binocularly from a distance of 57 cm.

A "topping-up" method of adaptation was used. The adapting stimulus was presented for periods of 5 sec, alternating with 1 sec exposures of the test field. The aftereffect was measured with a nulling staircase method. At each test presentation a beep sounded and the subject was required to press one of two keys. If the test field appeared to be brightening he or she struck the first key, which applied a dimming counterramp that made the *next* test field become physically dimmer over its 1-sec time-course. Conversely, if the test field appeared to be dimming he struck the second key, which applied a brightening counterramp that made the *next* test field become physically lighter over its 1-sec time-course. Thus the subject homed in over time on a nulling counterramp that made the test field appear subjectively to be neither dimming nor brightening. The slope of this counterramp indicated the strength of the ramp aftereffect. The subject now pressed a third key to express his satisfaction with the match; his setting was recorded, and after a short pause to allow the aftereffect to dissipate, the computer selected and presented the next stimulus.

The adapting waveform was a repetitive ramp or sawtooth applied to the Z (luminance) input of the CRO. Four temporal frequencies (0.5, 1, 2 and 4 Hz) and three amplitudes (5, 10, 20 dB) of this adapting ramp were used.

In each block of twelve trials all twelve combinations of frequency and amplitude were presented in random order under computer control. Three blocks of trials were presented to each subject with rest periods in between. To reduce carryover effects, rising and falling adapting waveforms were presented during different morning or afternoon sessions.

The two authors and a third experienced observer (AH) were the subjects. Natural pupils were used. However, the results were also generally confirmed by three other subjects wearing 2 mm artificial pupils.

The equipment was calibrated by measuring the screen luminance directly with a Minolta Chromameter II while different d.c. voltages were applied to the Z (luminance) input of the CRO. It was found that over a 2-V input range the log-luminance output swept linearly over a range of 1 log unit (20 dB). For input ranges  $> 2 \text{ V}$  the log-luminance output became non-linear and so was not used.

##### Results

Results are shown as a three-dimensional plot in Fig. 2. The x- and y-axes show the frequency and amplitude of the adapting sawtooth waveform. The z-axis shows the strength of the dimming and brightening aftereffects, expressed as the nulling test slope in dB/sec that just canceled out the aftereffect. Note that in

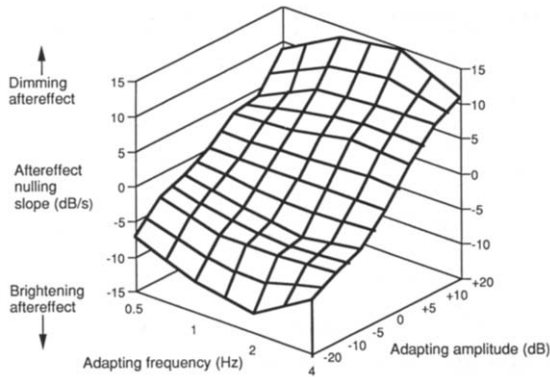

FIGURE 2. Three-dimensional plot of the results of Expt 1. Mean of two subjects. Aftereffect strength is expressed as the test slope in dB/sec that just nulled the aftereffect. Regions where  $z > 0$  are for the subjectively dimming aftereffects from a brightening ramp, and regions where  $z < 0$  are for subjectively brightening aftereffects from a dimming ramp.

all the graphs we have adopted the convention of inverting the  $y$ -axis, plotting dimming aftereffects from a rising ramp upwards, so that regions where  $z$  exceeds zero represent the subjectively dimming aftereffects from a brightening adapting waveform and vice versa for regions where  $z$  is below zero.

This three-dimensional plot is wedge shaped, sloping down from the rear where the adapting amplitude was +20 dB (rising ramp) towards the front where the adapting amplitude was -20 dB (falling ramp). This shows that the aftereffect was strongly dependent on the adapting amplitude, but was fairly independent of the

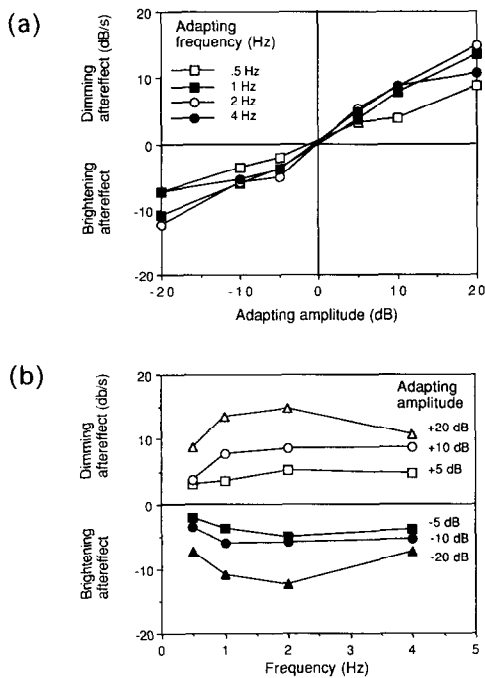

FIGURE 3. Results replotted by slicing the three-dimensional surface of Fig. 2 parallel to the  $x$ - and  $y$ -axes. Strength of the aftereffect is expressed as the test slope that just nulled out the aftereffect. (a) The aftereffect strength depended strongly upon the amplitude, or luminance range in dB, of the adapting ramp. (b) Horizontal curves show that aftereffect was relatively unaffected by the temporal repetition rate.

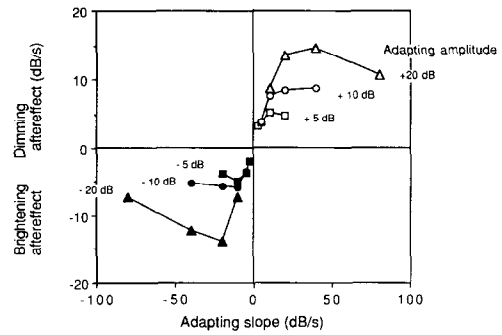

FIGURE 4. The aftereffect was not a linear function of the adapting slope. These curves are diagonal slices across the three-dimensional surface of Fig. 2.

adapting repetition rate. This is brought out more clearly in Fig. 3(a, b) which replots slices of the three-dimensional surface, cut parallel to the  $x$ - and  $y$ -axes.

In Fig. 3(a) all the lines slope upwards, showing that the aftereffect depends strongly upon the adapting amplitude, but the lines for different ramp repetition rates are superimposed, showing that repetition rate plays little part. Again, in Fig. 3(b), the spacing between the lines shows that all the aftereffects are strongly dependent upon the adapting amplitude, but all the lines are roughly horizontal, indicating that repetition rate plays little part in the aftereffect. It is true that the lines are slightly curved, concave toward zero, indicating that 1 and 2 Hz are the most effective repetition rates, but the change in aftereffect was always less than two-fold even for an eight-fold change in adapting frequency.

Figure 4 shows the effects of the adapting slope, which is simply the amplitude multiplied by the frequency. For instance a 2 Hz falling ramp of amplitude 20 dB has a slope of -40 dB/sec. If the nulling slope had been a constant percentage of the adapting slope, then the three curves in each quadrant of Fig. 4 would have been short lines that superimposed to form a single straight line. Instead, Fig. 4 shows that the nulling slope was a non-linear function of the adapting slope. These curves are replots of slices of the three-dimensional surface, cutting along diagonals which are parallel to the reader's line of sight in Fig. 2.

Figure 5 reveals a slight asymmetry between the aftereffects from rising and falling ramps. Figure 5(a) shows the foveal aftereffects of Expt 1 and Fig. 5(b) shows the foveal and peripheral aftereffects, both monocular and binocular, of Expt 2. If the aftereffects from rising and falling ramps were equal then all the points in Fig. 5(a, b) would have lain along the line of unit slope. In fact, however, nearly all the points lay below this line, showing that on average the subjectively brightening aftereffect produced by a dimming adapting ramp had only 81% [Fig. 5(a)] or 71% [Fig. 5(b)] of the slope of the subjectively dimming aftereffects produced by a brightening adapting ramp. Possibly the channels that respond to brightening are somewhat more sensitive or more numerous than those that respond to dimming.

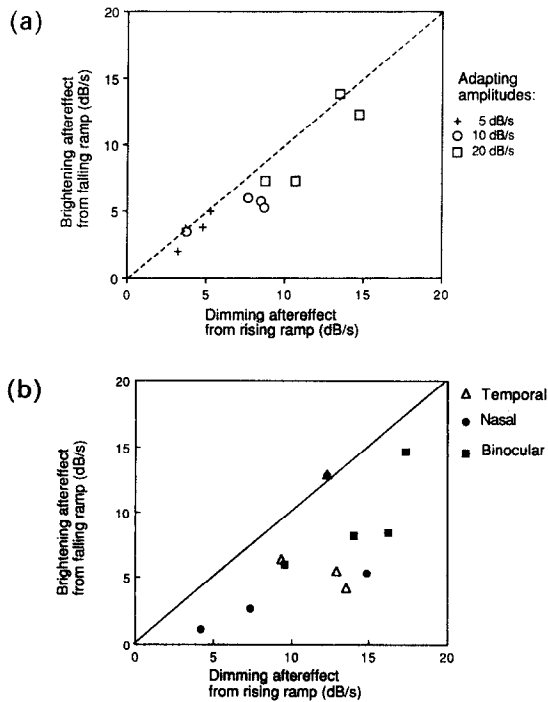

FIGURE 5. Asymmetry of aftereffects: rising ramps gave bigger aftereffects than falling ramps did. If both aftereffects had been equal, results would have lain along the lines of unit slope. In fact, however, results lay below this line, and on average the  $y$  values were only 81% (a) or 74% (b) of the  $x$  values. (a) Foveal aftereffects from Expt 1. Mean of two subjects. Symbols indicate adapting amplitudes: triangles, 20 dB; squares, 10 dB; circles, 5 dB. (b) Peripheral aftereffects from Expt 2. Squares, binocular viewing; circles, monocular nasal visual field; triangles, monocular temporal visual field.

#### EXPERIMENT 2: RAMP AFTEREFFECT AS A FUNCTION OF RETINAL ECCENTRICITY

The adapting ramp waveform was set to a repetition rate of 1 Hz and an amplitude of 17.8 dB. These values were similar to those that gave a strong aftereffect in Expt 1. The stimulus eccentricity was varied by providing seven fixation points, which were either in the center of the stimulus or displaced by 20, 30 or 40° to the left or right of the stimulus center. An eccentricity of 10° was not used because of the blind spot. The stimulus was viewed with the left eye, right eye, or binocularly. Each eccentricity and eye-condition was presented twice in random order, giving a total of 84 readings per observer (7 fixation positions  $\times$  3 eye conditions  $\times$  2 ramp-directions  $\times$  2 repetitions). Rising and falling waveforms were presented in separate blocks of trials. The surround was set to the arithmetic mean luminance, which was 34 cd/m<sup>2</sup>. In other respects the methods were the same as in Expt 1.

We looked for asymmetries between the nasal and temporal fields. For this purpose the readings taken when the left eye was fixating to the right of the stimulus were combined with those for the right eye fixating to the left of the stimulus to give readings for the temporal visual field; and left-eye readings during fixation to the left of the stimulus were combined with right-eye readings during fixation to the right of the stimulus to give readings for the nasal visual field.

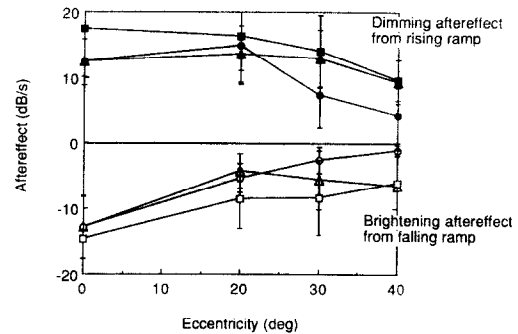

FIGURE 6. Aftereffects declined but did not disappear with increasing retinal eccentricities. Adapting amplitude 17.8 dB, repetition rate 1 Hz. Binocular aftereffects (squares) were larger than monocular, but temporal monocular aftereffects (triangles) were not significantly larger than nasal monocular aftereffects (circles). Vertical bars show  $\pm 1$  SE.

Results are shown in Fig. 6 (mean of two observers). Figure 6 shows that the aftereffect strength decreased with eccentricity. However, the aftereffect was clearly present out to an eccentricity of 40°. Binocular aftereffects were stronger than monocular; during the monocular trials the observers complained that the visual task was made more difficult by binocular rivalry coming from the patched (non-stimulated) eye and this might account for the superiority of binocular viewing. We found only a slight asymmetry between nasal and temporal visual fields: the temporal aftereffects were slightly, but not significantly stronger at eccentricities of 30 and 40° (based on a three-way ANOVA with a significance level of 0.05). We conclude that the visual channels responsible for the aftereffects, although most clearly in evidence in the fovea, are widely distributed across the retina.

#### EXPERIMENT 3: RAMP AFTEREFFECT AS A FUNCTION OF DARK-ADAPTATION

The adapting ramp waveform was set to a repetition rate of 1 Hz and an amplitude of 20 dB, as in Expt 1. Subjects fixated with their right eye a fixation point placed 10° below the stimulus. Neutral density filters of 0 (= no filter), 0.9, 1.8, 2.4 or 3.0 log units were placed over the eye. The observer dark-adapted to the 3.0 log unit filter for 25 min and then three readings were taken at each luminance, starting with the densest filter and

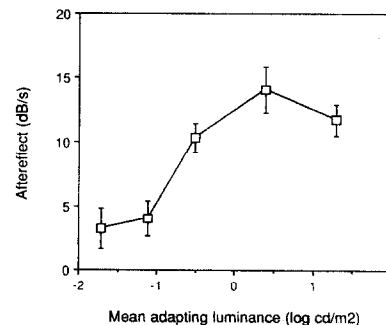

FIGURE 7. Aftereffects declined markedly at low (scotopic) luminance levels. Mean of two subjects, brightening adapting waveform, amplitude 20 dB, repetition rate 1 Hz, stimulus was 10° eccentric in upper visual field. Vertical bars show  $\pm 1$  SE.

working up systematically to no filter, in order to protect the dark-adapted state of the eye. In other respects the methods were the same as in Expt 1.

Results are shown in Fig. 7. Figure 7 shows that the aftereffect strength was maximum at high luminance levels, either with no filter or a pale (0.9 log units) filter, but decreased as the luminance level fell and as dark adaptation increased. We conclude that the aftereffect is primarily a photopic phenomenon. It is known that the dark-adapted retina has a sluggish temporal response, integrating dim stimuli over time when light is scarce in order to improve sensitivity at the expense of temporal resolution.

## DISCUSSION

The channels underlying the aftereffects are presumably transient channels that respond selectively to on- and off-(temporal increments and decrements of luminance). We have shown in earlier studies that the ramp aftereffect shows no interocular transfer (Anstis, 1967), so the underlying channels are presumably confined to the monocular pathways. The channels seem to have a coarse spatial grain; Anstis and Harris (1987) showed psychophysically that the diameters of their receptive fields were 20 times larger than those for acuity. They concluded that the transient channels are few in number and provide a coarse spatial sampling.

The outputs of the transient channels provide an input into motion detecting pathways (Anstis, 1986, 1990). The present study suggests that the channels are largely photopic and respond to the luminance range of the adapting ramp stimulus.

Our results from Expt 1 indicate that the aftereffect was driven strongly by the amplitude of the adapting waveform but less so by its repetition rate or by its slope in dB/sec. We conclude that the underlying visual channels have a preferred luminance range of at least 20 dB (1 log unit) and respond best to stimuli that sweep through this entire range. (Actually the preferred luminance range may be  $> 20$  dB, but apparatus limitations prevented us from exploring this possibility.) However, the visual channels are rather insensitive to the temporal rate at which the stimulus sweeps through this preferred range. It is as though the channels respond to the direction of successive differences in luminance over time, but are not sharply tuned to the rate of change. An analogy in the domain of motion detection would be a neural sequence discriminator that responded to direction and extent of motion but not to velocity.

Experiment 1 also showed that the ramp aftereffects were asymmetrical: the subjectively dimming aftereffects from a brightening adapting waveform were slightly larger than vice versa. Possibly the channels that respond to brightening are somewhat more sensitive or more numerous than those that respond to dimming.

Experiments 2 and 3 showed that the visual channels responsible for the aftereffects, although most clearly in evidence in the fovea, are widely distributed across the retina and can be found at eccentricities out at least as

far as  $40^\circ$ . They operate best during light adaptation and become progressively less active as dark adaptation is increased. We conclude that the aftereffects are primarily a photopic phenomenon, presumably arising in broad-band luminance pathways that receive inputs from R and G cones. It is unlikely that opponent-hue pathways are involved, since several researchers (F. W. Campbell, B. P. Moulden, D. M. Regan, personal communications at various times), as well as the authors have looked for aftereffects of swept wavelength and failed to find them.

### *Physiological mechanisms*

We can speculate about the physiological pathways that are being adapted during our psychophysical experiments. Possible candidates include brightening and dimming channels (Jung, 1961, 1973), on- and off-channels (Schiller, 1982, 1984; Schiller, Sandell & Maunsell, 1986), sustained and transient channels (Enroth-Cugell & Robson, 1966; Lennie, 1980), or magnocellular and parvocellular pathways (Livingstone & Hubel, 1988).

Jung (1973) summarized evidence for the existence in many animals of two distinct groups of visual neurons, responsive respectively to increase and decrease in luminance. For instance, Jacobs (1965) recorded the responses of two types of cell in the LGN of the squirrel monkey in which the luminance of a  $15^\circ$  diameter disk was shifted in stepped increments from an adaptation level. Some cells ("excitatory") increased their firing rate in response to increases in luminance and decreased their firing rate in response to decreases in luminance, whereas other cells ("inhibitory") showed the opposite pattern of responses. The luminance range that affected firing rate was about  $\pm 1$  log unit. Responses were greater at high levels of adapting luminance. This would be consistent with the larger aftereffects we found for the light-adapted than the dark-adapted observer.

Jung also suggested (1961) that analogous B and D channels signal "brightening" and "dimming" in the human visual system. Our results are consistent with these proposed B and D channels.

Schiller *et al.* (1986) studied on- and off-pathways, which respond primarily to light and dark spots. Retinal ganglion cells fall into two classes: on-center and off-center. The on-center cells respond best to a light spot or spatial luminance increment and the off-center cells respond best to a dark spot or luminance decrement. Both types show an initial transient response, or rapid burst of firing at stimulus onset, which levels down to a sustained response. Thus, in the vertebrate retina visual information is segregated into an on-channel excited by spatio-temporal light increment and an off-channel excited by spatio-temporal light decrement. Could our procedures be selectively adapting the transient responses of these on- and off-channels?

The on-channel can be selectively and reversibly blocked by the glutamic acid analog 2-amino-4-phosphonobutyric acid (APB) infused or injected into the vitreous of the rabbit (Knapp & Mistel, 1983) or rhesus monkey (Schiller, 1982, 1984; Schiller *et al.*, 1986). APB

blocked both the center and the surround responses of on-center cells, but had little effect on off-center cells. This implies that on- and off-channels originating in the retina remain functionally separated at the level of the LGN, but interact in the striate cortex. The value of segregating on from off information may be that it yields equal sensitivity and rapid information transfer for both incremental and decremental stimuli and facilitate high contrast sensitivity. Nature places a high premium upon speed of information processing in the animal kingdom, both for predators seeking out prey and for prey attempting to avoid predators.

One might think that adapting to a brightening field might be equivalent to a dose of APB, in that both treatments may reversibly desensitize the on-pathways. But this is probably not so, since Schiller (1984) found that APB preferentially blocked the sustained rather than the transient component (see Lennie, 1980) of the response of on-center cells. Furthermore, it is likely that luminance ramps are primarily adapting magnocellular pathways, since these respond to transient signals whereas parvocellular pathways are, on the whole, more responsive to sustained signals (Livingstone & Hubel, 1988). However, Schiller (1984) found that APB preferentially blocked parvocellular rather than magnocellular cells. We hypothesize that whereas APB blocks the sustained, parvocellular on responses, our rising and falling luminance ramps may be modifying the transient, magnocellular on and off responses respectively.

#### *Asymmetry of increments vs decrements*

We found in Expts 1 and 2 that the dimming aftereffects from a rising ramp were larger than the brightening aftereffects from a falling ramp. In other words, luminance increments are a more effective adapting stimulus. There are scattered references in the literature to asymmetries in the detection of luminance increments vs decrements, but no clear pattern emerges.

Krauskopf (1980) found that the human threshold for detecting a step or pulse change in luminance was slightly higher (0.025–0.12 log units) for increments than for decrements. The discrimination threshold—deciding whether a given luminance change was an increment or a decrement—was 0.5–0.7 log units higher than the detection threshold.

Patel and Jones (1968) measured human increment and decrement thresholds for stimuli ranging from 15 to 4.3° diameter and repeated durations of 20–1000 msec, at a retinal position 7° from the fovea. A light or a dark spot abruptly appeared in the center of a gray adapting field. They found that the increment threshold (for seeing a light spot) was consistently higher (0.01–0.3 log units) than the decrement threshold.

On the other hand, Ehrenstein and Spillmann (1983) measured the time threshold for increments and decrements in luminance (light and dark spots). In most conditions, increments and decrements had the same thresholds. For some conditions only, using eccentric vision at low background luminances, the time threshold for decrements progressively exceeded that for incre-

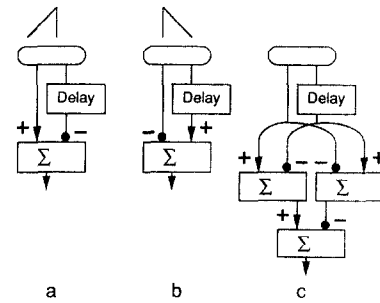

FIGURE 8. Model of pathways selective for brightening and dimming. See text.

ments, up to 80 msec. Thus Krauskopf (1980) and Patel and Jones (1968) found higher thresholds for increments, but Ehrenstein and Spillmann (1983) found occasionally higher thresholds for decrements.

Jacobs (1965) measured the Weber fraction ( $dI/I$ ) for excitatory and inhibitory cells in the LGN of the squirrel monkey and found that luminance discrimination was better in the increment direction at low adaptation luminances, but better in the decrement direction at high adaptation luminances.

These somewhat conflicting reports shed little light on our finding that rising ramps are more effective adaptors than falling ramps.

#### *A model*

Figure 8(a) shows a simple model of a temporal-derivative filter that would respond to temporal luminance increments ( $dI/dt$ ). A summation unit receives two inputs from a single retinal region: a direct input and a delayed input that signal respectively the present and the immediately past luminance. Subtracting the delayed from the direct input gives zero signal for an unchanging luminance and a positive signal for a brightening field.

In Fig. 8(b) the + and - inputs to the summation unit are reversed, so this pathway responds to luminance decrements (dimming).

In Fig. 8(c) the brightening detector of Fig. 8(a) and the dimming detector of Fig. 8(b) both send their outputs to a third summation unit, whose net output will be positive for a brightening field and negative for a dimming field. Note that this model is equivalent to a motion detector (Hassenstein & Reichardt, 1956; Barlow & Levick, 1985) with zero spatial shift. These motion devices receive inputs from two adjacent retinal regions and detect motion from one region to the other, whereas our model receives two inputs from the *same* retinal region.

It will be noticed that the output of the simple brightening detector of Fig. 8(a) will be positive for brightening and negative for dimming, just like the combined summary of Fig. 8(c). Physiologically, lateral inhibition could effectively reverse the sign of the Fig. 8(a) output, thus signaling both brightening and dimming in a single channel. Our two aftereffects, of illusory brightening and illusory dimming, could conceivably occur at different times within a single channel. But Hanly and Mackay (1979) found that a rising

adapting ramp elevated the threshold for detecting small increments of luminance twice as much as for decrements and vice versa. This asymmetrical change in thresholds could not occur in a single channel, so it is good evidence for two separate channels, one for brightening and the other for dimming. We conclude that these data support a two-channel model.

Krauskopf (1980) did the opposite experiment. Whereas Hanly and Mackay found that the slow phase of the temporal sawtooth made it harder to see a test ramp, Krauskopf found that the *fast* phase of the adapting sawtooth made it harder to see a test *step* or pulse. His adapting stimulus varied in a sawtooth fashion from darkness to 450 cd/m<sup>2</sup> at a rate of 1 Hz. A sawtooth with a fast phase upward raised the thresholds for incremental steps more than for decremental steps. A sawtooth with a fast phase downward raised the thresholds for decremental steps more than for incremental steps. Again this asymmetrical change in thresholds supports a two-channel model. A balanced (zero) output from Fig. 8(c) signifies a stimulus that is neither brightening nor dimming. Adaptation to luminance increments or decrements unbalances the bridge (Sutherland, 1961), giving rise to a non-zero output which is interpreted as an aftereffect of illusory brightening or dimming.

#### *Motion perception and luminance change*

There are two well known models of directional selectivity. In Reichardt's sequence discrimination model (Hassenstein & Reichardt, 1956), the signals from two adjacent retinal regions are compared; the delayed signal from one region is correlated with the non-delayed signal from the other. If the stimulus transit time in the preferred direction is equal to the neural delay, there is a strong output. Marr and Ullman's (1981) spatio-temporal derivative model uses change in stimulus luminance over space and time at just one position to infer movement. Mather (1984) combined uniform brightening and dimming fields, similar to ours, with stationary contours and obtained reports of apparent motion, even though there was no sequential change in edge location. The perceived directions were as one would predict from the Marr-Ullman model. Moulden and Begg (1986) demonstrated a threshold elevation for motion detection that was specific to edge polarity and to direction of adaptation phase and they also found that adapting their observers to a brightening or dimming uniform field (similar to ours) raised their threshold for seeing the motion of a black/white or white/black edge, again as predicted from the Marr-Ullman model. [But see Webb and Wenderoth (1989) for objections.]

The pathways sensitive to changes in luminance over time that we have examined have just the properties that are required as the temporal component in the Marr-Ullman model. At the same time, these pathways, as modeled in Fig. 8, are equivalent to Reichardt (or rather Barlow & Levick) motion detectors for a zero-distance motion. Thus our results are equally consistent with both models. We also obtained indirect evidence,

which we shall not detail here, that our luminance-change units provide an input into motion detectors (Anstis, 1990).

#### REFERENCES

- Anstis, S. M. (1967). Visual adaptation to gradual changes of intensity. *Science*, 155, 710-712.
- Anstis, S. M. (1986). Recovering motion information from luminance. *Vision Research*, 26, 147-160.
- Anstis, S. M. (1990). Motion aftereffects from a motionless stimulus. *Perception*, 19, 301-306.
- Anstis, S. M. & Harris, J. P. (1987). Magnification factor for adaptation of a visual transient mechanism. *Journal of the Optical Society of America A*, 4, 1688-1698.
- Barlow, H. B. & Levick, W. R. (1965). Mechanism of directionally selective units in the rabbit's retina. *Journal of Physiology, London*, 178, 477-504.
- Cavanagh, P. & Anstis, S. M. (1986). Brightness shift in drifting ramp gratings isolates a transient mechanism. *Vision Research*, 26, 899-908.
- Ehnenstein, W. H. & Spillmann, L. (1983). Time thresholds for increments and decrements in luminance. *Journal of the Optical Society of America*, 73, 419-426.
- Enroth-Cugell, C. & Robson, J. (1966). The contrast sensitivity of retinal ganglion cells of the cat. *Journal of Physiology, London*, 187, 517-522.
- Gardner, R. B. & Wilson, J. P. (1979). Evidence for direction-specific channels in the processing of frequency modulation. *Journal of the Acoustical Society of America*, 66, 704-709.
- Hanly, M. & MacKay, D. M. (1979). Polarity-sensitive perceptual adaptation to temporal sawtooth modulation in luminance. *Experimental Brain Research*, 35, 37-46.
- Hassenstein, B. & Reichardt, W. (1956). Systemtheoretische Analyse der Zeit-Reihenfolgen und Vorzeichenbewertung bei der Bewegungsperzeption des Rüsselkäfers *Chlorophanus*. *Zeitschrift für Naturforschung*, 11b, 513-524.
- Jacobs, G. H. (1965). Effects of adaptation on the lateral geniculate response to light increment and decrement. *Journal of the Optical Society of America*, 55, 1535-1540.
- Jung, R. (1961). Korrelationen von Neuronentätigkeit und Sehen. In Jung, R. & Kornhuber, H. H. (Eds), *Neurophysiologie und Psychophysik des visuellen Systems* (pp. 410-435). Berlin: Springer.
- Jung, R. (1973). Visual perception and neurophysiology. In Jung, R. (Ed.), *Handbook of sensory physiology*, VII/3 (pp. 1-152). Berlin: Springer.
- Kay, R. H. & Matthews, D. R. (1972). On the existence in human auditory pathways of channels selectively tuned to the modulation present in frequency-modulated tones. *Journal of Physiology*, 225, 657-677.
- Knapp, A. D. & Mistler, L. A. (1983). Response properties of cells in rabbit's lateral geniculate nucleus during reversible blockade of retinal on-center channels. *Journal of Neurophysiology*, 50, 1236-1245.
- Krauskopf, J. (1980). Discrimination and detection of changes in luminance. *Vision Research*, 20, 671-677.
- Lennie, P. (1980). Parallel visual pathways: A review. *Vision Research*, 20, 561-594.
- Livingstone, M. & Hubel, D. (1988). Segregation of form, color, movement and depth: Anatomy, physiology and perception. *Science*, 240, 740-749.
- Marr, D. & Ullman, S. (1981). Directional selectivity and its use in early visual processing. *Proceedings of the Royal Society of London, B*, 211, 151-180.
- Mather, G. (1984). Luminance change generates apparent movement: Implications for models of directional specificity in the human visual system. *Vision Research*, 24, 1399-1405.
- Moulden, B. P. & Begg, H. (1986). Some tests of the Marr-Ullman model of movement detection. *Perception*, 15, 139-155.
- Patel, A. S. & Jones, R. W. (1968). Increment and decrement visual thresholds. *Journal of the Optical Society of America*, 58, 696-699.

- Regan, D. & Tansley, B. W. (1979). Selective adaptation to frequency-modulated tones: Evidence for an information-processing channel selectively sensitive to frequency changes. *Journal of the Acoustical Society of America*, *65*, 1249–1257.
- Reinhardt-Rutland, A. H. & Anstis, S. M. (1982). Auditory adaptation to gradual rise or fall in intensity of a tone. *Perception and Psychophysics*, *31*, 63–67.
- Schiller, P. H. (1982). Central connections of the retinal ON and OFF pathways. *Nature*, *297*, 580–583.
- Schiller, P. H. (1984). The connections of the retinal on and off pathways to the lateral geniculate nucleus of the monkey. *Vision Research*, *24*, 923–932.
- Schiller, P. H., Sandell, J. H. & Maunsell, J. H. (1986). Functions of the ON and OFF channels of the visual system. *Nature*, *322*, 824–835.
- Sutherland, N. S. (1961). Visual discrimination of horizontal and vertical rectangles by rats on a new discrimination apparatus. *Quarterly Journal of Experimental Psychology*, *13*, 117–121.
- Webb, B. & Wenderoth, P. (1989). Some additional predictions and further tests of the Marr-Ullman model of motion perception. *Perception*, *18*, 753–765.
- Zaidi, Q. & Halevy, D. (1990). Mechanisms that signal color changes. *Investigative Ophthalmology and Visual Science (Suppl.)*, *31*, 110.

---

*Acknowledgements*—KA was supported by a research fellowship from the Deutsche Forschungsgemeinschaft and by a research associateship from the Institute of Space and Terrestrial Sciences. SMA was supported by Grant A2606 from the Natural Science and Engineering Research Council of Canada (NSERC). We thank Dr Alan Ho for acting as a subject in Expt 2. We would like to thank Dr Otmar Bock for providing time to complete this publication.